

On-Premise Laundry Planning Handbook

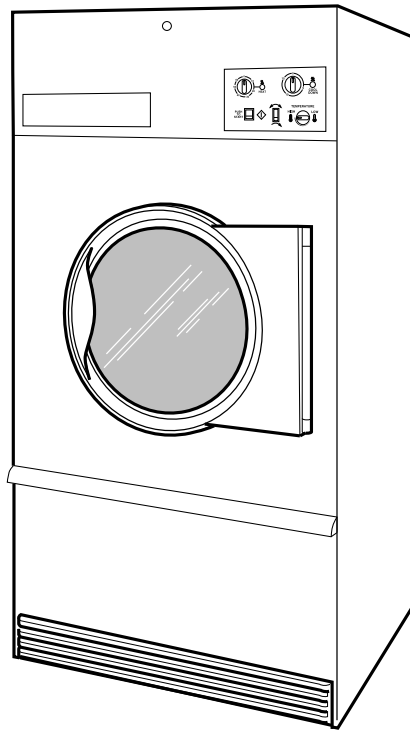

TM795C

50 and 75 Pound Tumblers Starting Serial No. 0904004427

Refer to Installation manual for full instructions.



Table of Contents

Tumblers – 50 and 75	2
Introduction	2
Model Identification	2
Specifications and Dimensions	4
Cabinet Dimensions	5
Exhaust Outlet Locations.....	6
Gas Connection Locations.....	7
Electrical Connection Locations.....	8
Steam Connection Locations	9
Installation.....	10
Pre-Installation Inspection	10
Tumbler Enclosure.....	11
Exhaust Requirements	12
Layout	12
Make-Up Air.....	12
Venting	12
Individual Venting.....	13
Manifold Venting.....	15
50 Pound Gas and Steam Models	18
75 Pound Gas and Steam Models	19
50 and 75 Pound Electric Models	20

© Copyright, Alliance Laundry Systems LLC

All rights reserved. No part of the contents of this book may be reproduced or transmitted in any form or by any means without the expressed written consent of the publisher.

Tumblers – 50 and 75

Introduction

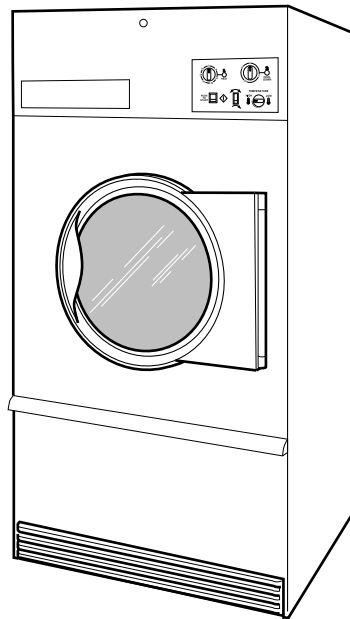

TMB795C

Model Identification

	Gas		Steam/Thermal Oil		Electric
50 Pound	IPD50G2-IT050L	IPD50G2-IT050N	IPD50S2-IT050S	IPD50S2-IT050T	IPD50E2-IT050E
75 Pound	IPD75G2-IT075L	IPD75G2-IT075N	IPD75S2-IT075S	IPD75S2-IT075T	IPD75E2-IT075E

Includes models with the following control suffixes:

3V – DX4 vended
 3X – DX4 prep for coin
 DO – DMP OPL
 EO – LED OPL

QT – dual digital timer
 RD – reversing DMP OPL
 RE – reversing LED OPL
 RQ – reversing dual digital timer

SD – single drop
 SX – single drop, prep for coin

Tumblers – 50 and 75

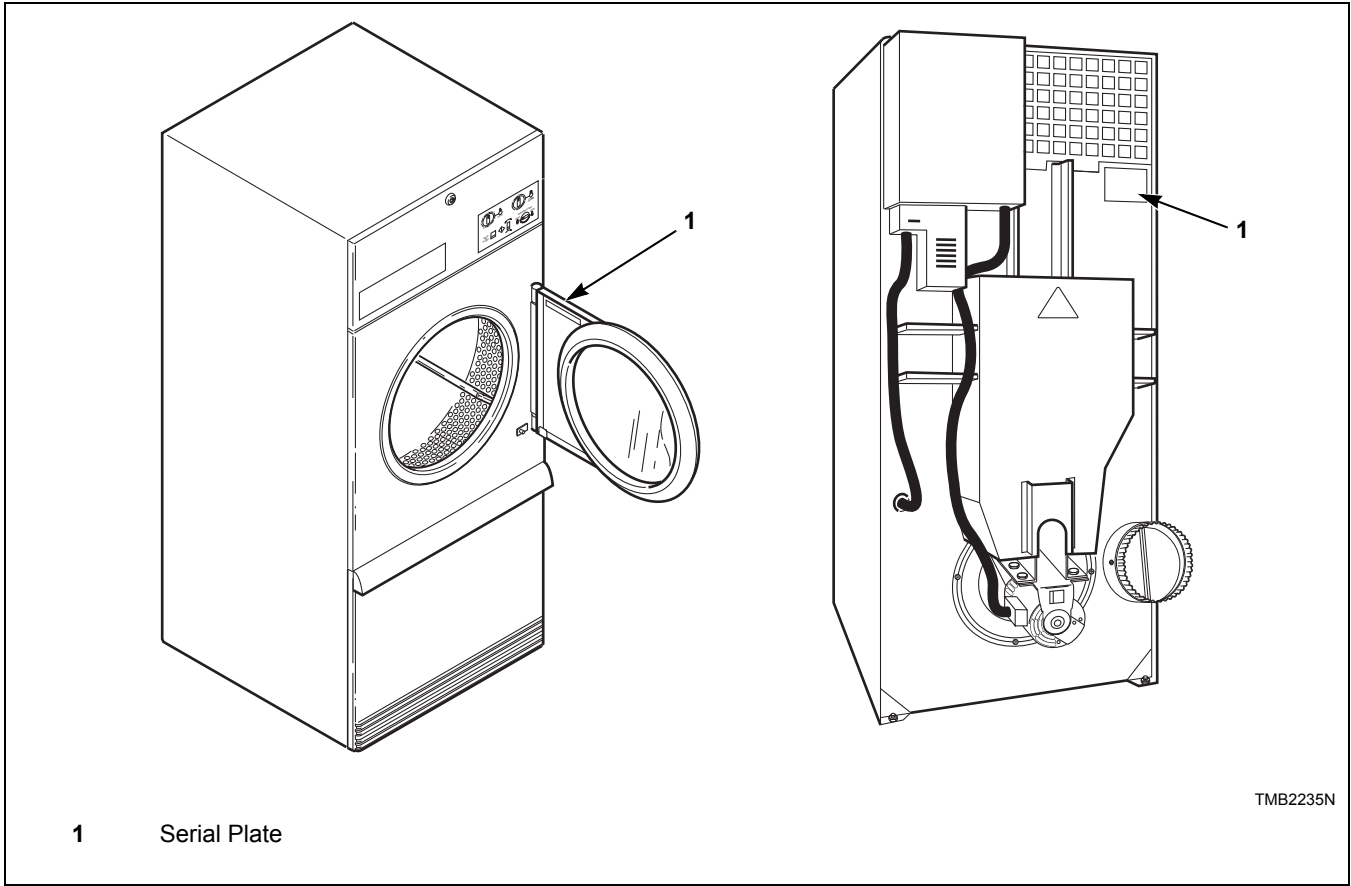

Conversion Table						
Multiply	By	To Obtain		Multiply	By	To Obtain
Btu	0.252	kCal		Pounds/sq. inch	0.06895	Bars
Btu	1055	Joules		Pounds/sq. inch	0.070	kg/sq. cm
Inch	25.4	Millimeters		Pounds (lbs.)	0.454	Kilograms
Inches W.C.	0.036	Pounds/sq. inch		Boiler Horsepower	33,479	Btu/hr.
Inches W.C.	0.249	kPa		Boiler Horsepower	34.5	lbs. steam/hr.
lb/inch ² (psi)	6.895	kPa		CFM	0.471	liters/second
ft ³	28.32	Liters		kW	3414	Btu/hr.

Specifications and Dimensions

Specifications	50 Pound	75 Pound
Noise level measured during operation at operator position of 3.3 feet (1 meter) in front of machine and 5.2 feet (1.6 meters) from floor.	60 dBA	65 dBA
Net Weight (approximate): Pounds (kg)	545 (247)	615 (279)
Cylinder Size: Inches (mm)	37 x 30 (940 x 762)	37 x 36 (940 x 914)
Cylinder Capacity (dry weight): Pounds (kg)	50 (22.7)	75 (34)
Air Outlet Diameter: Inches (mm)	8 (203)	8 (203)
Maximum Static Back Pressure: W.C.I. (mbar)	0.5 (1.3)	0.5 (1.3)
Maximum Airflow: C.F.M. (L/sec.)	750 (354)	Gas/Steam 60 Hz 920 (434) Gas/Steam 50 Hz 750 (354) Electric 750 (354)
Motor Horsepower: Nonreversing Reversing Fan Cylinder	1/2 1/3 1/3	3/4 1/3 1/3
Gas Models		
Gas Connection	1/2 in. NPT	1/2 in. NPT
Gas Burner Rating: Btu/hr (Mj/hr.)	130,000 (137.2)	165,000 (174.1)
Electric Models		
Heating Element Rating: Kilowatts (kW)	21 kW (240 V/50 Hz) 30 kW (other voltages)	30 kW
Steam Models		
Steam Connection	3/4 in. NPT	3/4 in. NPT
Steam Coil Rating at 100 psig: Boiler Horsepower (Btu/hr.) (recommended operating pressure 80-100 psig)	5.1 (177,500)	6.1 (210,300)

N/A = Not Applicable

Cabinet Dimensions

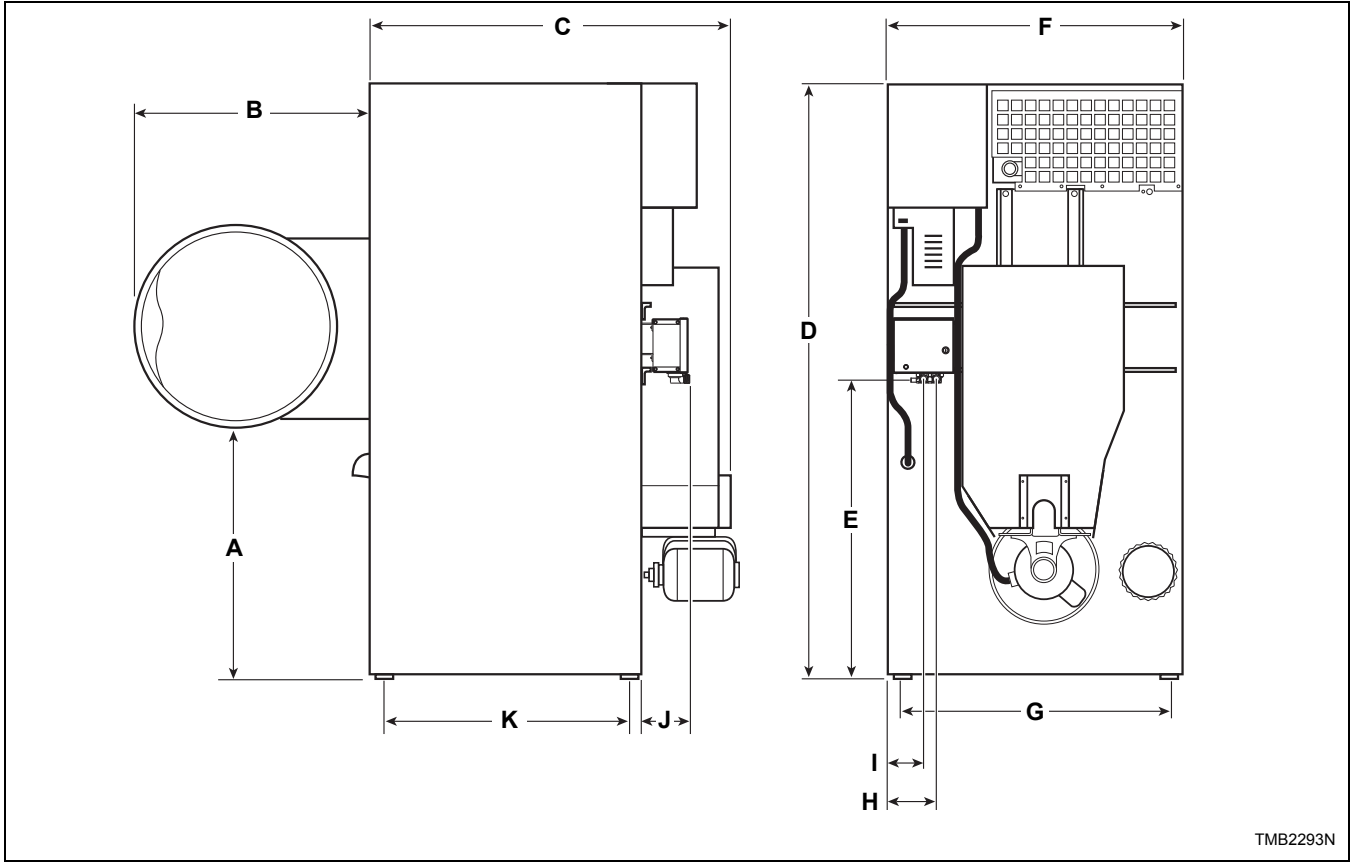

TMB2293N

Models	A	B	C	D	E*	F
50 Pound Gas and Electric	30.75 in. (781 mm)	33.87 in. (860 mm)	48.25 in. (1226 mm)	76.625 in. (1946 mm)	36 in. (914 mm)	38.625 in. (981 mm)
50 Pound Steam	30.75 in. (781 mm)	33.87 in. (860 mm)	48.25 in. (1226 mm)	80 in. (2032 mm)	36 in. (914 mm)	38.625 in. (981 mm)
75 Pound Gas and Electric	30.75 in. (781 mm)	33.87 in. (860 mm)	54.25 in. (1378 mm)	76.625 in. (1946 mm)	36 in. (914 mm)	38.625 in. (981 mm)
75 Pound Steam	30.75 in. (781 mm)	33.87 in. (860 mm)	54.25 in. (1378 mm)	80 in. (2032 mm)	36 in. (914 mm)	38.625 in. (981 mm)

Models	G	H*	I*	J*	K
50 Pound Gas and Electric	33 in. (838 mm)	7.1 in. (180 mm)	5.5 in. (140 mm)	6.53 in. (166 mm)	29.5 in. (749 mm)
50 Pound Steam	33 in. (838 mm)	7.1 in. (180 mm)	5.5 in. (140 mm)	6.53 in. (166 mm)	29.5 in. (749 mm)
75 Pound Gas and Electric	33 in. (838 mm)	7.1 in. (180 mm)	5.5 in. (140 mm)	6.53 in. (166 mm)	35.5 in. (902 mm)
75 Pound Steam	33 in. (838 mm)	7.1 in. (180 mm)	5.5 in. (140 mm)	6.53 in. (166 mm)	35.5 in. (902 mm)

* Fire suppression system optional - may not be on machine.

Exhaust Outlet Locations

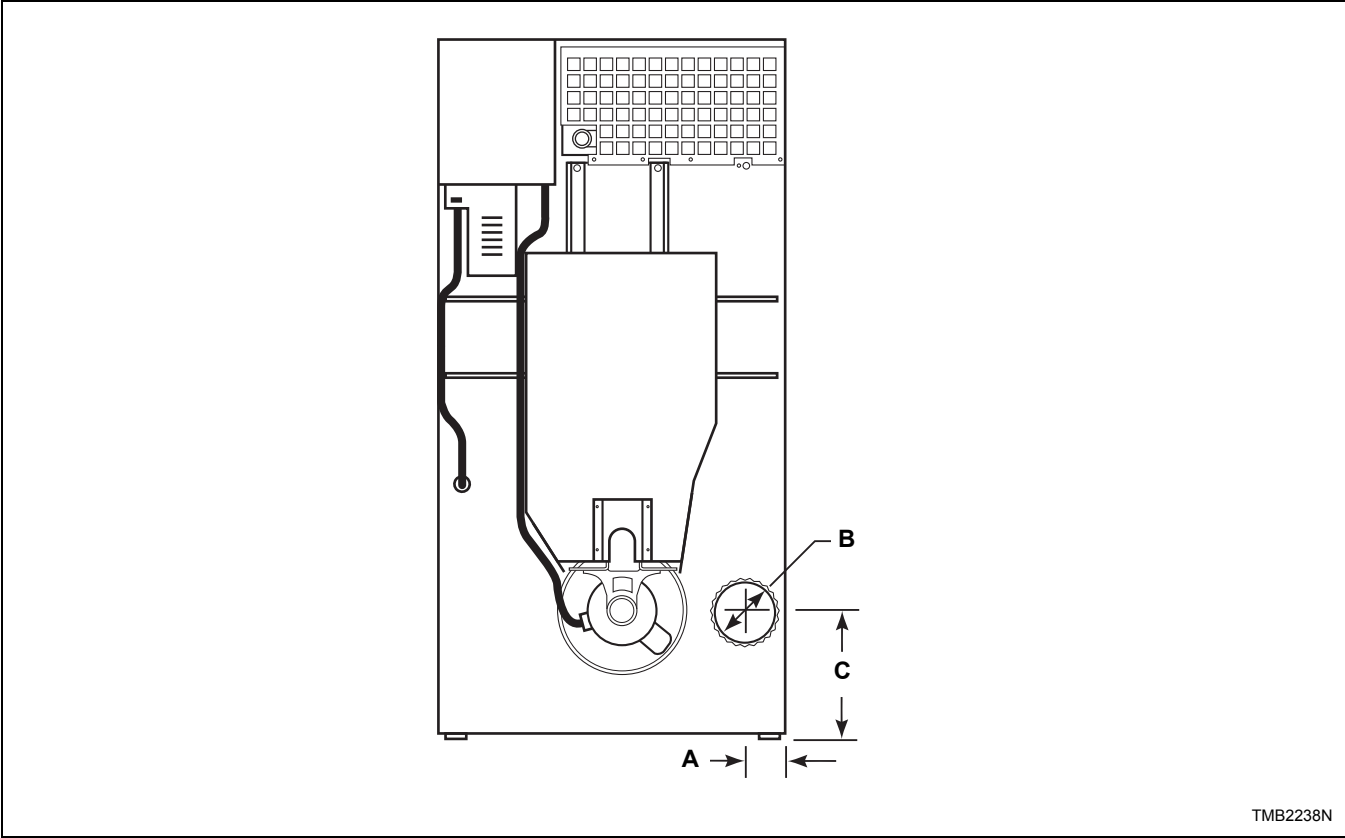

TMB2238N

A	B	C
5.375 in. (137 mm)	8 in. (203 mm)	13.375 in. (340 mm)

Tumblers – 50 and 75

Gas Connection Locations

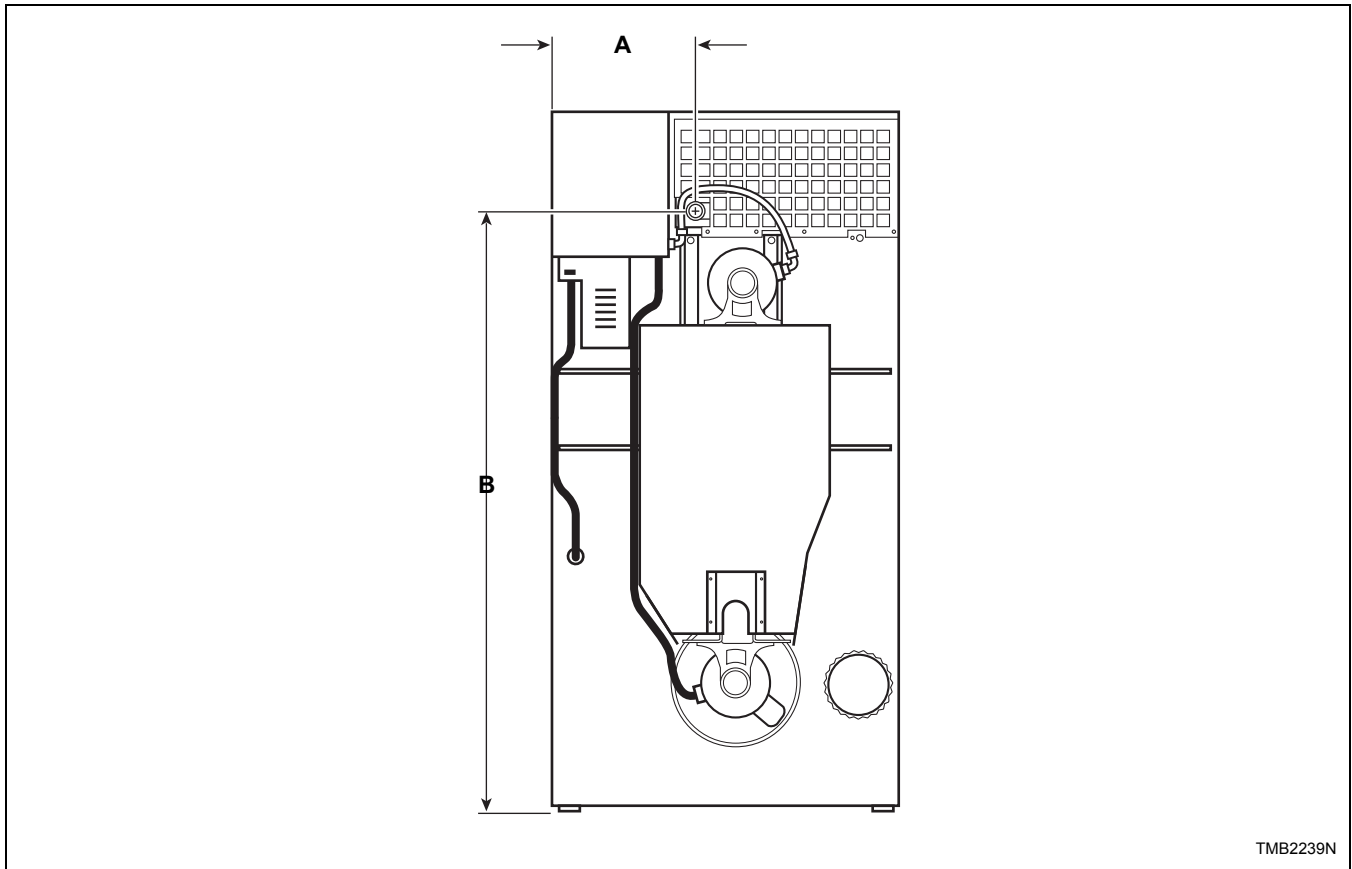

Diameter	A	B
3/4 in. NPT	14.75 in. (375 mm)	65.75 in. (1670 mm)

Electrical Connection Locations

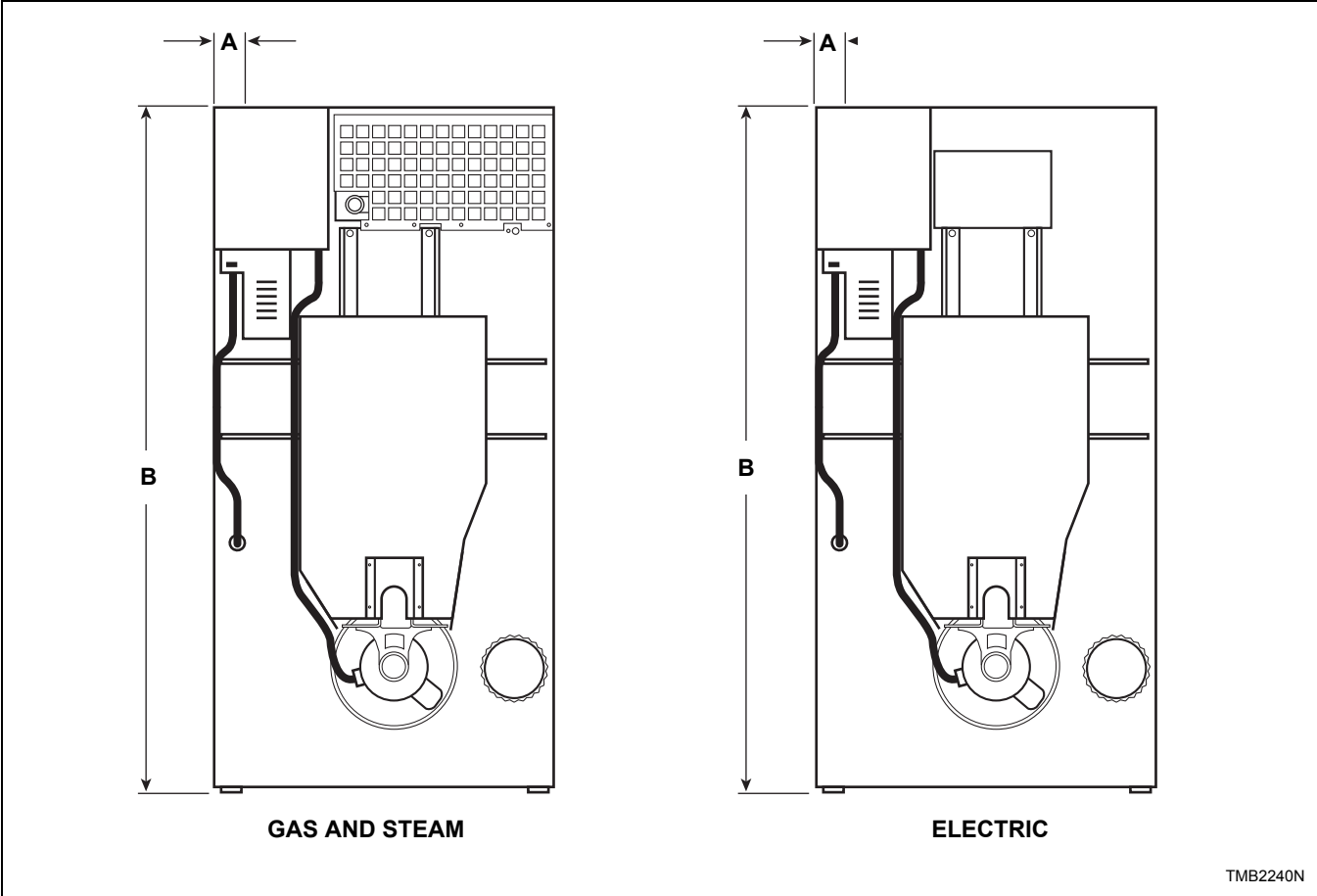

TMB2240N

A	B
3.25 in. (83 mm)	75.5 in. (1918 mm)

NOTE: These figures are approximate dimensions only.

Steam Connection Locations

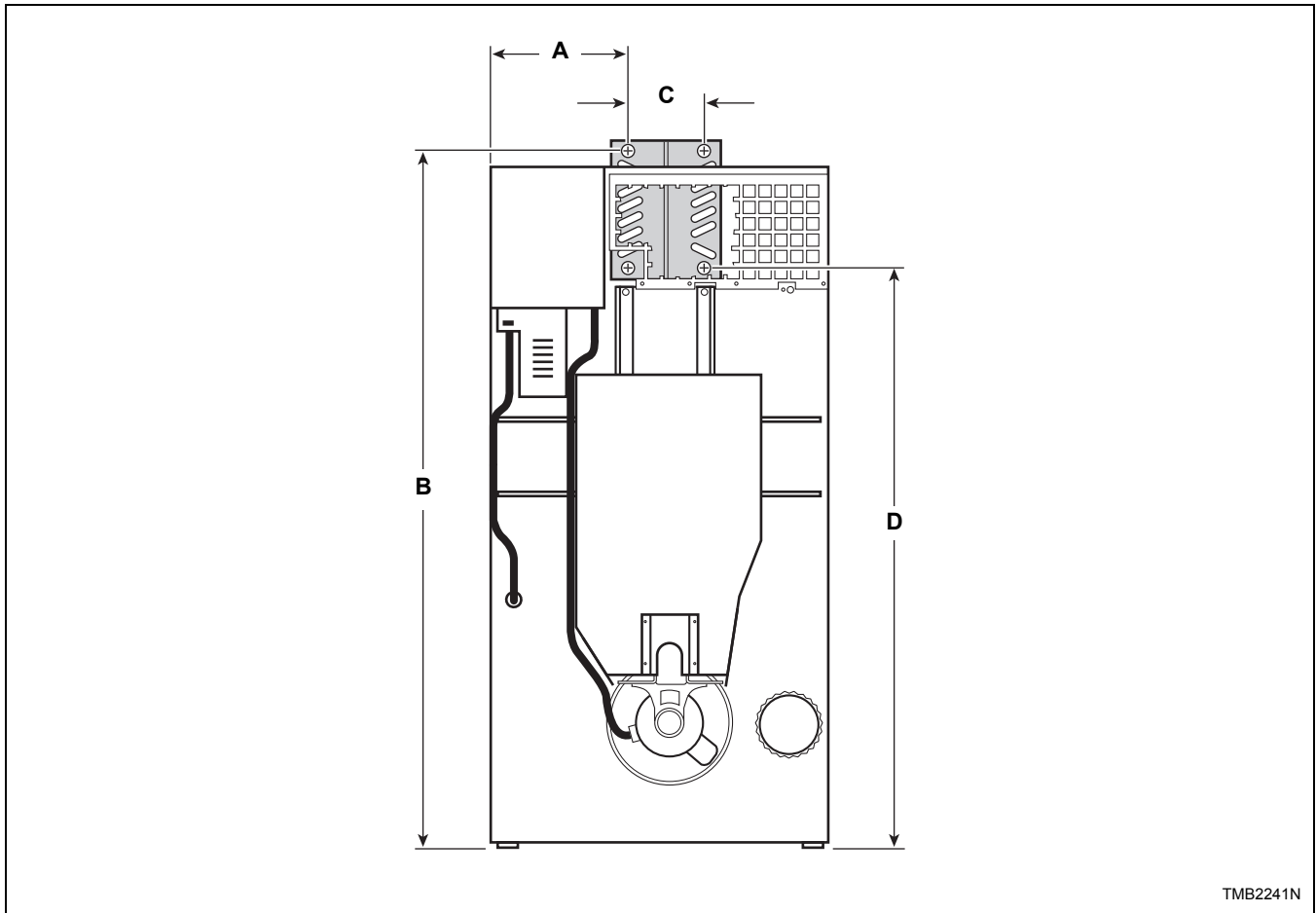

TMB2241N

Diameter	A	B	C	D
3/4 in. NPT	15.5 in. (394 mm)	78.25 in. (1988 mm)	7.5 in. (190 mm)	64.75 in. (1645 mm)

Installation

Pre-Installation Inspection

Upon delivery, visually inspect the crate, carton and parts for any visible shipping damage. If the crate, carton, or cover is damaged or signs of possible damage are evident, have the carrier note the condition on the shipping papers before the shipping receipt is signed, or advise the carrier of the condition as soon as it is discovered.

Remove the crate and protective cover as soon as possible and check the items listed on the packing list. Advise the carrier of any damaged or missing articles as soon as possible. A written claim should be filed with the carrier immediately if articles are damaged or missing.

IMPORTANT: Warranty is void unless tumbler is installed according to instructions in this manual. Installation should comply with minimum specifications and requirements detailed herein, and with applicable local gas fitting regulations, municipal building codes, water supply regulations, electrical wiring regulations, and any other relevant statutory regulations. Due to varied requirements, applicable local codes should be thoroughly understood and all pre-installation work arranged for accordingly.

Tumbler Enclosure

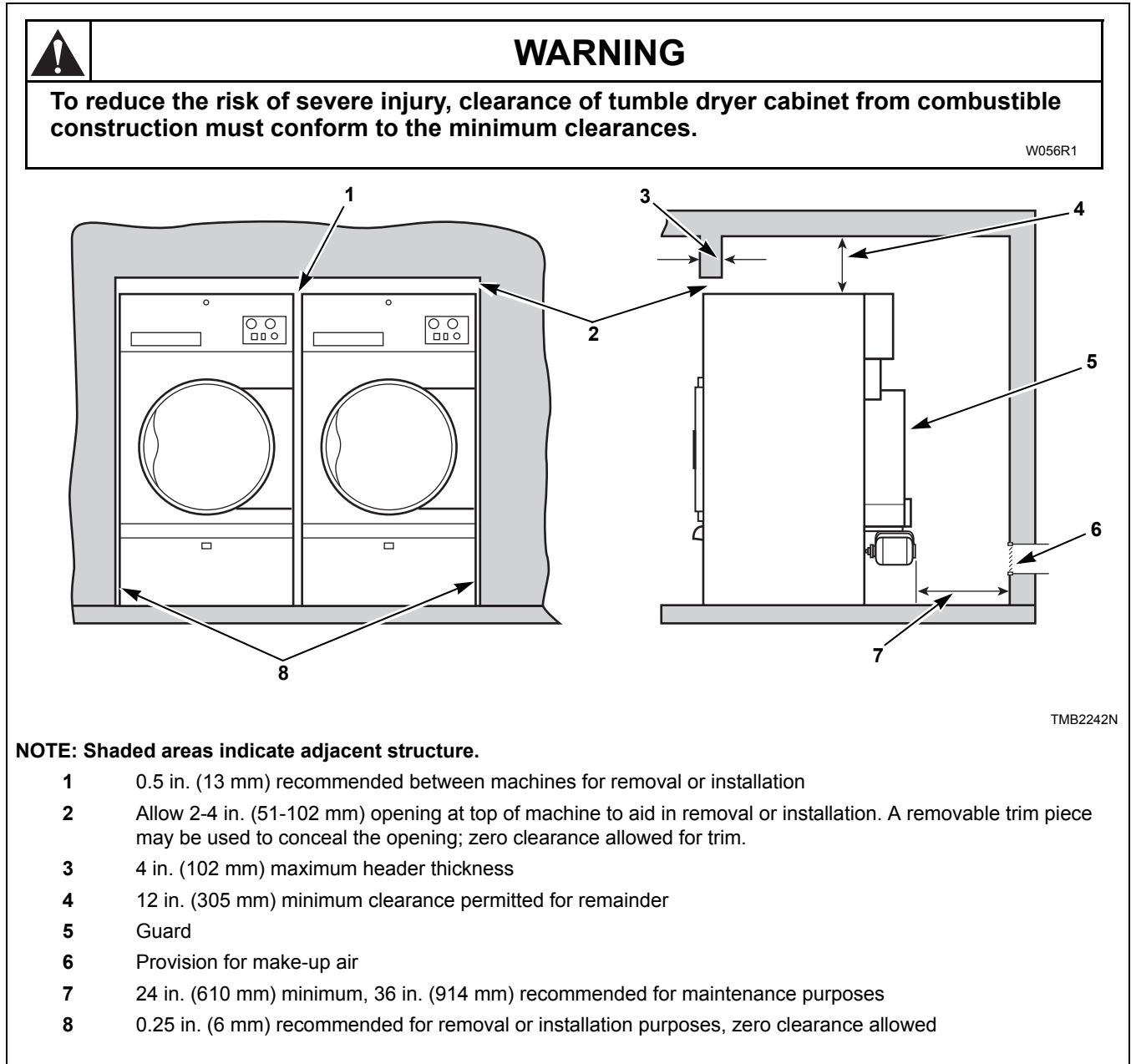



Figure 1

Exhaust Requirements

	WARNING
<p>A drying tumble dryer produces combustible lint. To reduce the risk of fire, the tumble dryer must be exhausted to the outdoors.</p> <p style="text-align: right;">W057R1</p> <p>To reduce the risk of fire and accumulation of combustible gases, DO NOT exhaust tumble dryer air into a window well, gas vent, chimney or enclosed, unventilated area such as an attic wall, ceiling, crawl space under a building, or concealed</p>	

Layout

Whenever possible, install tumblers along an outside wall where duct length can be kept to a minimum, and make-up air can be easily accessed. Elbows and long vents tend to increase drying time. Construction must not block the airflow at the rear of the tumbler. Doing so would prevent adequate air supply to the tumbler’s combustion chamber.

Make-Up Air

A tumbler is forced air exhausted and requires provisions for make-up air to replace the air exhausted by the tumbler.

IMPORTANT: Do not obstruct the flow of combustion and ventilation air.

Make-up air openings should be as close to the tumbler(s) as possible.

The required make-up air opening to the outside for each tumbler is:

Required Make-Up Air Opening (to the outside) for Each Tumbler	
Model	Opening
50 Pound	144 in ² (928 cm ²)
75 Pound	195 in ² (1258 cm ²)

Make-up air openings with louvers will restrict airflow. The opening must be increased to compensate for area taken up by louvers.

Make-up air openings for a room containing tumbler(s) and/or gas fired hot water heater or other gravity vented appliances must be increased sufficiently to prevent downdrafts in any of the vents when all tumblers are in operation. Do not locate gravity vented appliances between tumbler(s) and make-up air openings. If it is necessary to duct make-up air to the tumbler(s), increase the area of the ductwork by 25% to compensate for any restriction in air movement.

Venting

	WARNING
<p>To reduce the risk of fire due to increased static pressure, we do not recommend installation of in-line secondary lint filters or lint collectors. If secondary systems are mandated, frequently clean the system to assure safe operation.</p> <p style="text-align: right;">W749</p>	

IMPORTANT: Installing in-line filters or lint collectors will cause increased static pressure. Failure to maintain the secondary lint system will decrease tumbler efficiency and may void machine warranty.

For maximum efficiency and minimum lint accumulation, tumbler air must be exhausted to the outdoors by the shortest possible route.

Proper sized exhaust ducts are essential for proper operation. All elbows should be sweep type. Exhaust ducts must be assembled so the interior surfaces are smooth, so the joints do not permit the accumulation of lint. DO NOT use plastic or thin foil ducts - rigid metal ducts are recommended. Use exhaust ducts made of sheet metal or other noncombustible material. DO NOT use sheet metal screws or fasteners on exhaust pipe joints which extend into the duct and catch lint. Use of duct tape or pop-rivets on all seams and joints is recommended, if allowed by local code.

Verify that old ducts are thoroughly cleaned out before installing new tumbler(s).

	WARNING
<p>Improperly sized or assembled ductwork causes excess back pressure which results in slow drying, lint collecting in the duct, lint blowing back into the room, and increased fire hazard.</p> <p style="text-align: right;">W355</p>	

Tumblers – 50 and 75

NOTE: Exhaust ducts must be constructed of sheet metal or other noncombustible material. Such ducts must be equivalent in strength and corrosion resistance to ducts made of galvanized sheet steel not less than 0.0195 inches (0.495 mm) thick. Local codes may require additional thickness.

Where the exhaust duct pierces a combustible wall or ceiling the opening must be sized per local codes. The space around the duct may be sealed with noncombustible material. Refer to *Figure 2*.

IMPORTANT: For best performance provide an individual exhaust duct for each tumbler. Do not install a hot water heater in a room containing tumblers. It is better to have the water heater in a separate room with a separate air inlet.

Individual Venting

For maximum efficiency and performance, it is preferred to exhaust tumbler(s) individually to the outdoors.

IMPORTANT: At no point may the cross sectional area of installed venting be less than the cross sectional area of the exhaust outlet of the tumbler.

The exhaust duct must be designed so the static back pressure measured 12 inches (305 mm) from the exhaust outlet does not exceed the maximum allowable pressure specified on the installation sticker on the rear of the tumbler.

NOTE: Static back pressure must be measured with the tumbler running.

The maximum allowable length venting of the same diameter as the exhaust thimble is 14 feet (4.3 m) and two 90° elbows or equivalent. If the equivalent length of a duct required for an installation exceeds the maximum allowable equivalent length, the diameter of a round duct must be increased by 10% for each additional 20 feet (6.1 m). Cross section area of a rectangular duct must be increased by 20% for each additional 20 feet (6.1 m). Refer to *Table 1* to determine equivalent venting.

NOTE: The maximum length of a flexible metal duct must not exceed 7.87 ft. (2.4 m) as required to meet UL2158, clause 7.3.2A.

Duct Diameter	Equivalent Length of Rigid Straight Duct
6 in. (152 mm)	One 90° elbow = 7 ft. (2.1 m)
8 in. (203 mm)	One 90° elbow = 9.3 ft. (2.83 m)
10 in. (254 mm)	One 90° elbow = 11.6 ft. (3.5 m)
12 in. (305 mm)	One 90° elbow = 14 ft. (4.3 m)
14 in. (356 mm)	One 90° elbow = 16 ft. (4.9 m)
16 in. (406 mm)	One 90° elbow = 18.7 ft. (5.7 m)
18 in. (457 mm)	One 90° elbow = 21 ft. (6.4 m)
Equivalent Length (feet) = 1.17 x Duct Diameter (inches)	

Table 1

Example: A 12 inch (305 mm) diameter duct’s equivalent length of 14 feet (4.3 m) of duct and two 90° elbows is:

$$\begin{aligned} \text{Equivalent Length} &= 14 \text{ feet} + (2) \text{ 90° elbows} \\ &= 14 \text{ feet} + 14 \text{ feet} + 14 \text{ feet} \\ &= 42 \text{ feet (12.8 meters)} \end{aligned}$$

With the tumbler in operation, airflow at any point in the duct should be at least 1200 feet per minute (366 meters per minute) to ensure that lint remains airborne. If 1200 feet per minute cannot be maintained, schedule monthly inspections and cleaning of the ductwork.

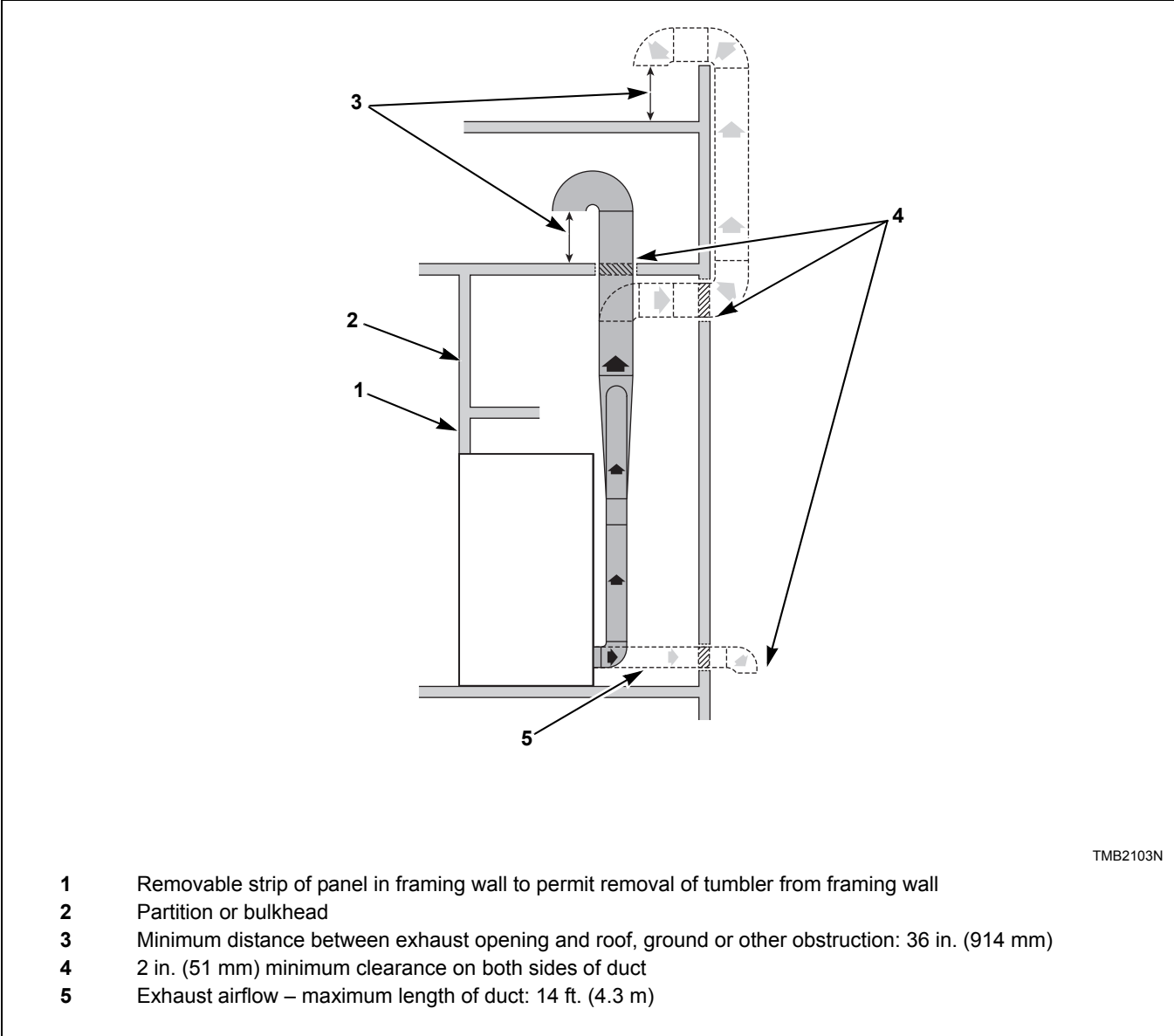

Figure 2

NOTE: Do not install wire mesh or screen in exhaust duct opening to avoid lint build-up or impacting proper discharge of air from tumblers.

NOTE: Where exhaust duct pierces a combustible wall or ceiling, the opening must be sized per local codes.

NOTE: Inside of duct must be smooth. Do not use sheet metal screws to join sections.

Consult your local building code for regulations which may also apply.

Manifold Venting

While it is preferable to exhaust tumblers individually to the outdoors, a main collector duct may be used if it is sized according to *Figure 4* and *Figure 5*. This illustration indicates minimum diameters, which should be increased if the collector length exceeds 14 feet (4.3 meters) and two 90° elbows. The diameter of a round duct must be increased by 10% for each additional 20 feet (6.1 meters). Cross sectional area of a rectangular or square duct must be increased 20% for each additional 20 feet (6.1 meters). Refer to *Table 2* and *Table 3* to determine equivalent ducting sizing. The collector duct may be rectangular or square in cross section, as long as the area is not reduced. Provisions **MUST** be made for lint removal and cleaning of the collector duct.

The vent collector system must be designed so the static back pressure measured 12 inches (305 mm) from the exhaust outlet does not exceed the maximum allowable pressure specified on the installation sticker on the rear of tumbler. Static back pressure must be measured with all tumblers vented into the collector operating.

NOTE: Never connect a tumbler duct at a 90° angle to the collector duct. Refer to *Figure 3*. Doing so will cause excessive back pressure, resulting in poor performance. Never connect two tumbler exhaust ducts directly across from each other at the point of entry to the collector duct.

With the tumbler in operation, airflow at any point in the duct should be at least 1200 feet per minute (366 meters per minute) to ensure that lint remains airborne. If 1200 feet per minute cannot be maintained, schedule monthly inspections and cleaning of the ductwork.

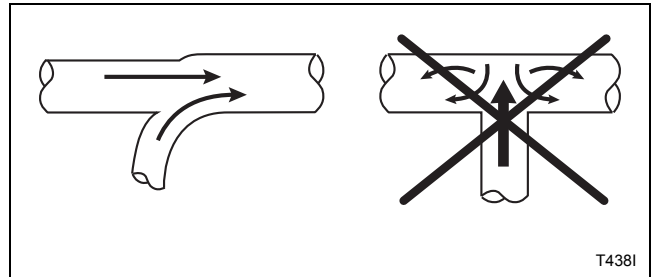

Figure 3

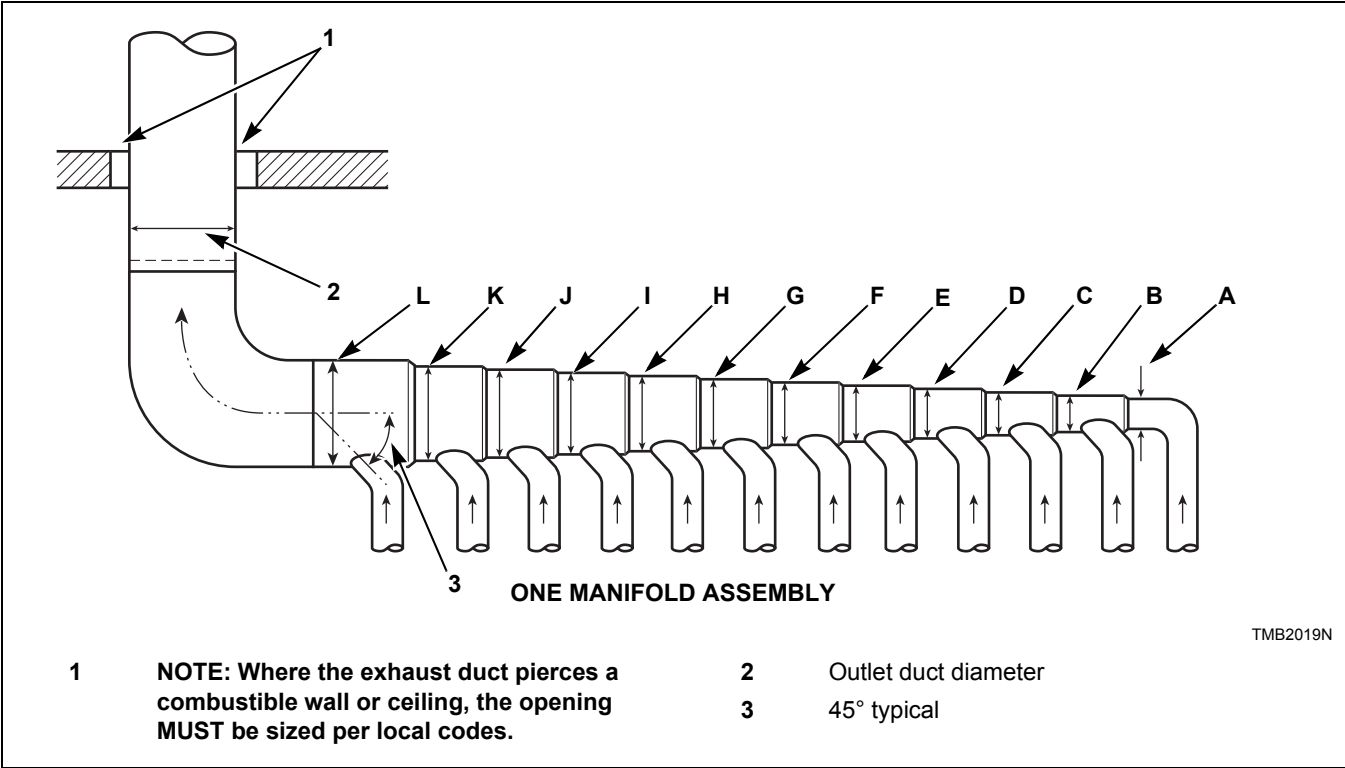

Figure 4

Duct Station	8 in. (203 mm) Duct
A	8 in. (203 mm)
B	12 in. (305 mm)
C	15 in. (381 mm)
D	17 in. (432 mm)
E	19 in. (483 mm)
F	21 in. (533 mm)
G	23 in. (584 mm)
H	25 in. (635 mm)
I	26 in. (660 mm)
J	27 in. (686 mm)
K	29 in. (737 mm)
L	30 in. (762 mm)

Table 2

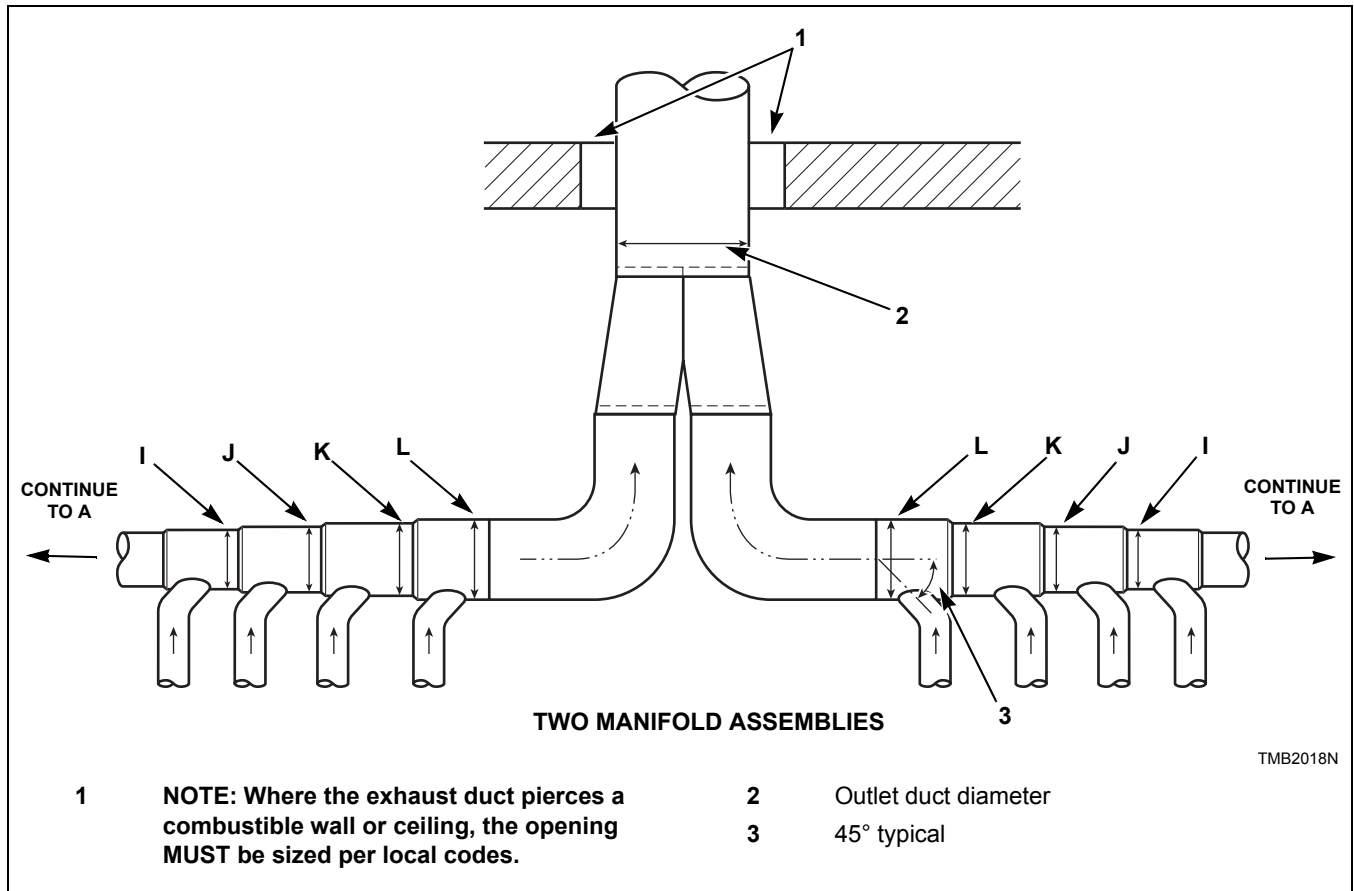

Figure 5

Duct Station	8 in. (203 mm) Duct
A	13 in. (330 mm)
B	17 in. (432 mm)
C	18 in. (457 mm)
D	24 in. (610 mm)
E	27 in. (686 mm)
F	30 in. (762 mm)
G	33 in. (838 mm)
H	34 in. (864 mm)
I	37 in. (940 mm)
J	39 in. (991 mm)
K	40 in. (1016 mm)
L	42 in. (1067 mm)

Table 3

50 Pound Gas and Steam Models

Refer to *Table 4*.

NOTE: Wire sizes were obtained from the Canadian Electrical Code for 75 C. wire and are intended for use as a guideline only. Electrical connections should be made by a qualified electrical contractor in accordance with all applicable local and national requirements.

NOTE: Electrical specifications below are subject to change without notice. Always refer to product serial plate for most current specifications of product being installed.

NOTE: Use copper conductors only.

NOTE: Connect to individual branch circuit.

NOTE: 3 Phase Only – Each tumbler must be connected to its own individual branch circuit breaker, not fuses, to avoid the possibility of “single phasing” and causing premature failure of the motor(s).

Serial Plate Rating	Terminal Block Connections Required	Serial Plate Amps		Recommended Circuit	
		Nonreversing	Reversing	Breaker Rating	Wire Size AWG (mm ²)
120V/60Hz/1ph	L1, Neutral and ground	9.3	N/A	15A – 1 pole	14 (2.08)
200-208V/60Hz/1ph	L1, Neutral and ground	5.1	N/A	10A – 1 pole	14 (2.08)
200-208-240V/60Hz/1ph	L1, L2 and ground	5.1	N/A	10A – 2 pole	14 (2.08)
230-240V/50Hz/1ph	L1, Neutral and ground	6.3	6.9	15A – 1 pole	14 (2.08)
200-208V/60Hz/3ph	L1, L2, L3 and ground	2.8	4.0	10A – 3 pole	14 (2.08)
200V/50Hz/3ph	L1, L2, L3 and ground	3.3	4.2	10A – 3 pole	14 (2.08)
240V/60Hz/3ph	L1, L2, L3 and ground	2.8	4.0	10A – 3 pole	14 (2.08)
230-240V/50Hz/3ph	L1, L2, L3 and ground	3.1	4.3	10A – 3 pole	14 (2.08)
380V/50 or 60Hz/3ph	L1, L2, L3 and ground	1.6	2.0	10A – 3 pole	14 (2.08)
400-415V/50Hz/3ph	L1, L2, L3 and ground	1.6	2.0	10A – 3 pole	14 (2.08)
440V/60Hz/3ph	L1, L2, L3 and ground	1.4	1.9	10A – 3 pole	14 (2.08)
460-480V/60Hz/3ph	L1, L2, L3 and ground	1.4	1.9	10A – 3 pole	14 (2.08)

N/A = Not Applicable

Table 4

75 Pound Gas and Steam Models

Refer to *Table 5*.

NOTE: Wire size and breaker ratings were obtained from the Canadian Electrical Code for 75 C. wire and are intended for use as a guideline only. Electrical connections should be made by a qualified electrical contractor in accordance with all applicable local and national requirements.

NOTE: Electrical specifications below are subject to change without notice. Always refer to product serial plate for most current specifications of product being installed.

NOTE: Use copper conductors only.

NOTE: Connect to individual branch circuit.

NOTE: 3 Phase Only – Each tumbler must be connected to its own individual branch circuit breaker, not fuses, to avoid the possibility of “single phasing” and causing premature failure of the motor(s).

Serial Plate Rating	Terminal Block Connections Required	Serial Plate Amps		Recommended Circuit	
		Nonreversing	Reversing	Breaker Rating	Wire Size AWG (mm ²)
120V/60Hz/1ph	L1, Neutral and ground	13.8	N/A	20A – 1 pole	12 (3.31)
200-208V/60Hz/1ph	L1, Neutral and ground	7.6	N/A	15A – 1 pole	14 (2.08)
200-208-240V/60Hz/1ph	L1, L2 and ground	7.6	N/A	15A – 2 pole	14 (2.08)
230-240V/50Hz/1ph	L1, Neutral and ground	6.7	7.0	15A – 1 pole	14 (2.08)
200-208V/60Hz/3ph	L1, L2, L3 and ground	3.8	4.3	10A – 3 pole	14 (2.08)
200V/50Hz/3ph	L1, L2, L3 and ground	3.5	4.5	10A – 3 pole	14 (2.08)
240V/60Hz/3ph	L1, L2, L3 and ground	3.8	4.3	10A – 3 pole	14 (2.08)
230-240V/50Hz/3ph	L1, L2, L3 and ground	3.5	4.9	10A – 3 pole	14 (2.08)
380V/50 or 60Hz/3ph	L1, L2, L3 and ground	1.8	2.1	10A – 3 pole	14 (2.08)
400-415V/50Hz/3ph	L1, L2, L3 and ground	1.8	2.1	10A – 3 pole	14 (2.08)
440V/60Hz/3ph	L1, L2, L3 and ground	1.9	2.1	10A – 3 pole	14 (2.08)
460-480V/60Hz/3ph	L1, L2, L3 and ground	1.9	2.1	10A – 3 pole	14 (2.08)

N/A = Not Applicable

Table 5

50 and 75 Pound Electric Models

Refer to *Table 6*.

NOTE: Wire size and breaker ratings were obtained from the Canadian Electrical Code for 75 C. wire and are intended for use as a guideline only. Electrical connections should be made by a qualified electrical contractor in accordance with all applicable local and national requirements.

NOTE: Electrical specifications below are subject to change without notice. Always refer to product serial plate for most current specifications of product being installed.

NOTE: Use copper conductors only.

NOTE: Connect to individual branch circuit.

NOTE: 3 Phase Only – Each tumbler must be connected to its own individual branch circuit breaker, not fuses, to avoid the possibility of “single phasing” and causing premature failure of the motor(s).

Serial Plate Rating	Terminal Block Connections Required	Serial Plate Amps		Recommended Circuit	
		Nonreversing	Reversing	Breaker Rating	Wire Size AWG (mm ²)
240V/50Hz/1ph (50 Pound only)	L1, Neutral and Ground	93	95	125A – 1 pole	1 (42.4)
200-208V/60Hz/3ph	L1, L2, L3 and ground	89	88	125A – 3 pole	1 (42.4)
200V/50Hz/3ph	L1, L2, L3 and ground	84	85	125A – 3 pole	1 (42.4)
230V/50Hz/3ph	L1, L2, L3 and ground	73	75	100A – 3 pole	3 (26.7)
240V/50Hz/3ph	L1, L2, L3 and ground	79	78	100A – 3 pole	3 (26.7)
240V/60Hz/3ph	L1, L2, L3 and ground	79	78	100A – 3 pole	3 (26.7)
380V/50 or 60Hz/3ph	L1, L2, L3 and ground	47	48	60A – 3 pole	6 (13.3)
400-415V/50Hz/3ph	L1, L2, L3 and ground	43	44	60A – 3 pole	6 (13.3)
440V/60Hz/3ph	L1, L2, L3 and ground	41	41	51A – 3 pole	6 (13.3)
480V/60Hz/3ph	L1, L2, L3 and ground	38	38	50A – 3 pole	6 (13.3)

Table 6